



# Residential Meter Loop Specs







# So, what is a Meter Loop?

## Use This Handy Guide to Complete the Process

### **What is a Meter Loop?**

A meter loop is the assembly that serves as the path for electrical conductors to securely attach to the house or pole and the electrical meter. It consists of the weatherhead, the service mast or riser, and the meter enclosure.

### **Who owns the Meter Loop?**

The member owns the meter loop and is responsible for upkeep and maintenance. The member may provide their own meter loop or purchase one from United. United maintains ownership of the meter itself.

### **What are the components/materials that make up the Meter Loop?**

The weatherhead, the service mast or riser, and the meter enclosure. In the case of an underground service, there will not be a weatherhead.

### **Who is responsible for purchasing and maintaining the Meter Loop?**

The member. If the meter loop is to be located on one of United's primary poles (high voltage), then it must be installed by United employees or contractors.

### **Is there much difference between underground and overhead service Meter Loops?**

Yes. Several common assemblies are illustrated in this handbook.

### **Overhead Clearances**

All overhead installations of 0 to 750 volts must meet the following minimum clearances set out by Table 232-1 of the NESC and the Texas Transportation Code.

### **Vertical Clearances**

- Track rails of railroads (except electrified railroads using overhead trolley conductors)—24.0 feet
- Roads, streets, and other areas subject to truck traffic—22.0 feet
- Driveways, parking lots, alleys—16.0 feet

**Residential Exception:** Where trucks are not expected to be encountered, then this clearance may be reduced to 12.0 feet.

- Other land traversed by vehicles, such as cultivated, grazing, forest, orchards, etc.—6.0 feet
- Spaces and ways subject to pedestrians or restricted traffic only—12.0 feet

**Residential Exception:** This clearance

may be reduced to 10.5 feet.

### **Buildings**

- Over or under roofs or projections not readily accessible to pedestrians—3.5 feet
- Over or under balconies and roofs readily accessible to pedestrians—11.0 feet
- Over roofs accessible to vehicles but not subject to truck traffic—11.0 feet
- Over roofs accessible to truck traffic—6.0 feet

\* For the purpose of these clearances, trucks are defined as vehicles exceeding 8 feet in height.

### **Horizontal Clearances**

#### **Buildings**

- To walls, projections, windows and balconies—5.0 feet
- Signs, chimneys, billboards, radio and television antennas, tanks and other installations not classified as buildings or bridges
- To portions that are readily accessible to pedestrians—5.0 feet
- To portions that are not readily accessible to pedestrians—3.5 feet

## Specifications for Self-Contained Meter Installations

The following meter loop specifications are intended for new and re-connect residential and small non-residential services only. Where service requirements exceed single-phase 120/240 volts and/or 320 amps, please contact United Cooperative Services for any adjustments and additional requirements.

The effective date of this document is April 27, 2017. All previous documents pertaining to United Cooperative Services meter loop specifications are superseded by this document and should be discarded.

It is the responsibility of the member to furnish, maintain and install or contract to install the meter loop. As an option to members, United Cooperative Services will provide and/or install an approved meter loop on a cooperative owned and installed pole at the member's expense. If a member chooses to provide their own meter loop, then United Cooperative Services will provide the meter socket/base at the member's request and expense.

This document contains requirements for meter loops, both overhead and underground. Several examples of constructions are shown in these specifications, but the examples provided within this document shall not be construed to be the only allowable installations. Regardless of actual construction details, all meter loop installations shall meet the following conditions before United Cooperative Services will provide electric service:

Installations and wiring must adhere to the current National Electric Code (NEC) and National Electric Safety Code (NESC), as well as any other applicable local, state or federal regulations or ordinances.

All meter loops must be equipped with a properly sized main disconnect located on the load side of the meter base. Locate the main disconnect as close as possible to the meter socket.



All new meter locations must be readily accessible by United Cooperative Services personnel, be relatively free from possible mechanical damage, and be surface mounted so as to allow for replacement or maintenance (i.e. meter loops/bases must not be made to be a permanent part of any structure).

The connections to the meter socket base shall be watertight. A watertight entrance conduit or weatherhead must be installed on the upper end of the conduit.

The member's wiring must be completed to the stage that a meter can be set and sealed without the need for later meter removal for completion of the member's wiring. United Cooperative Services will not energize a service that is judged by cooperative employee to be in violation of any regulatory code or cause an unsafe condition to people,

livestock or property.

All meter loops shall be grounded with a minimum of No. 6 copper conductor securely connected to a 5/8-inch diameter, 8-foot long copper ground rod. If the meter loop is purchased from United Cooperative Services, then the ground rod will be provided and installed by cooperative personnel.

Service entrance conductors may be copper, aluminum, or copper-clad aluminum only. Where aluminum conductors are used, all terminators must be rated to accept aluminum. See table on next page for minimum conductor sizes.

### CONTACT UCS OFFICES FOR PRICING. (817) 447-9292

Service Size	Ungrounded Conductor (AWG/kcmil)		Minimum Neutral (AWG/kcmil)		Rigid Conduit Size
	Copper	Aluminum/Copper-Clad Aluminum	Copper	Aluminum/Copper-Clad Aluminum	
100 Amp	#4	#2	#4	#2	1.25"
200 Amp	2/0	4/0	#1	2/0	2"
320 Amp	350	500	4/0	300	3"

## OVERHEAD TEMPORARY POLE

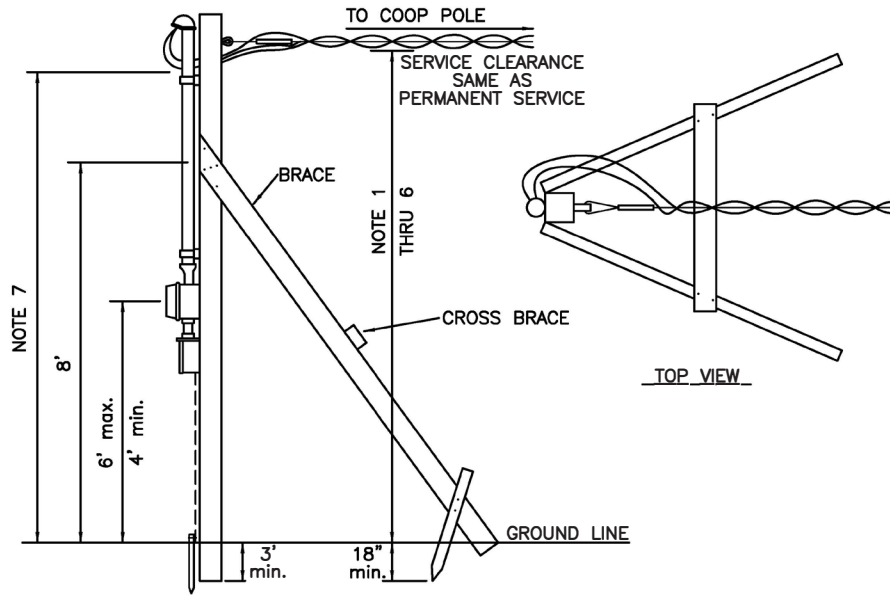

### TEMPORARY SERVICE

SINGLE  
PHASE  
120/240

1. Over walkways, platforms or areas not subject to vehicular traffic _____	12 ft.
2. Over residential driveways and commercial parking area not subject to truck traffic _____	12 ft.
3. Over commercial areas, parking lots or other areas subject to truck traffic _____	18 ft.
4. Over alleys and commercial driveways _____	18 ft.
5. Over streets and highways _____	22 ft.
6. Over roof where:	
Accessible to pedestrians * _____	8 ft.
Not accessible to pedestrians * _____	3 ft.
7. Drip loop _____	10 ft.

\* A roof, balcony, or area is considered accessible to pedestrians if the means of access is through a doorway, ramp, stairway, or permanently mounted ladder. A permanently mounted ladder is not considered a means of access if its bottom rung is 8 ft. or more from the ground or other permanently installed accessible surface.

## UNDERGROUND TEMPORARY POLE

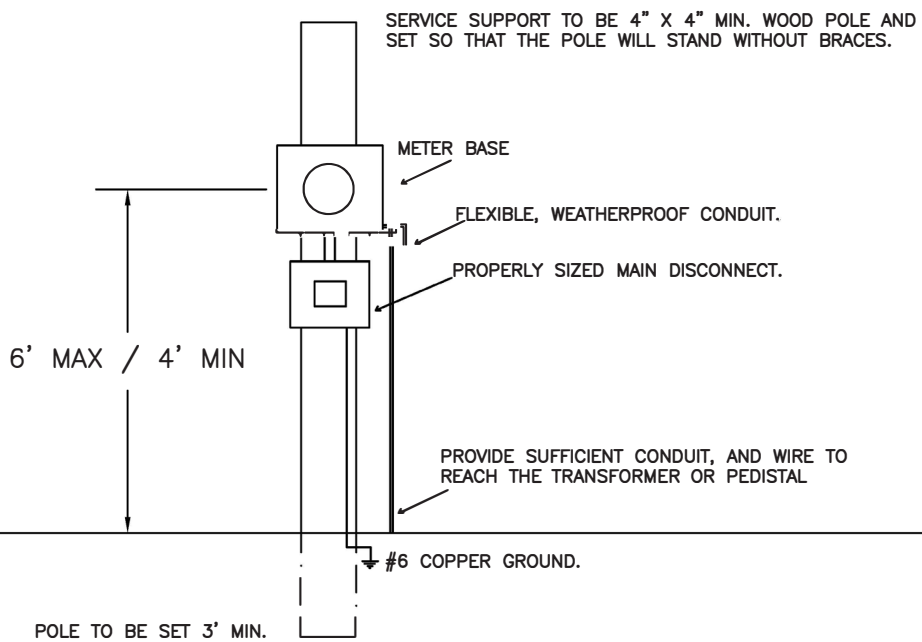



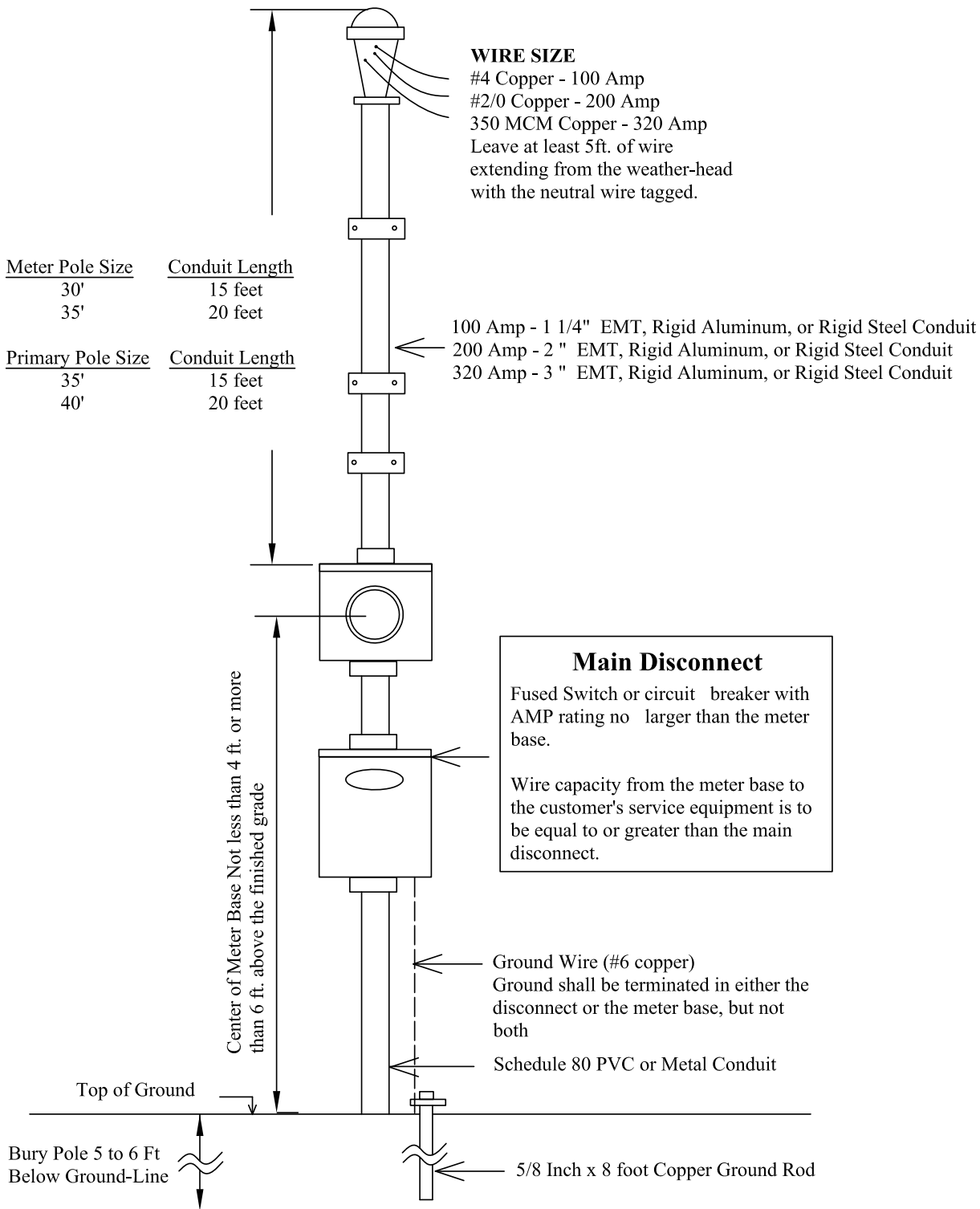

If the Member pays to have United hang the Member's meter loop, then the loop MUST be constructed of RIGID ALUMINUM (not EMT or Rigid Steel)

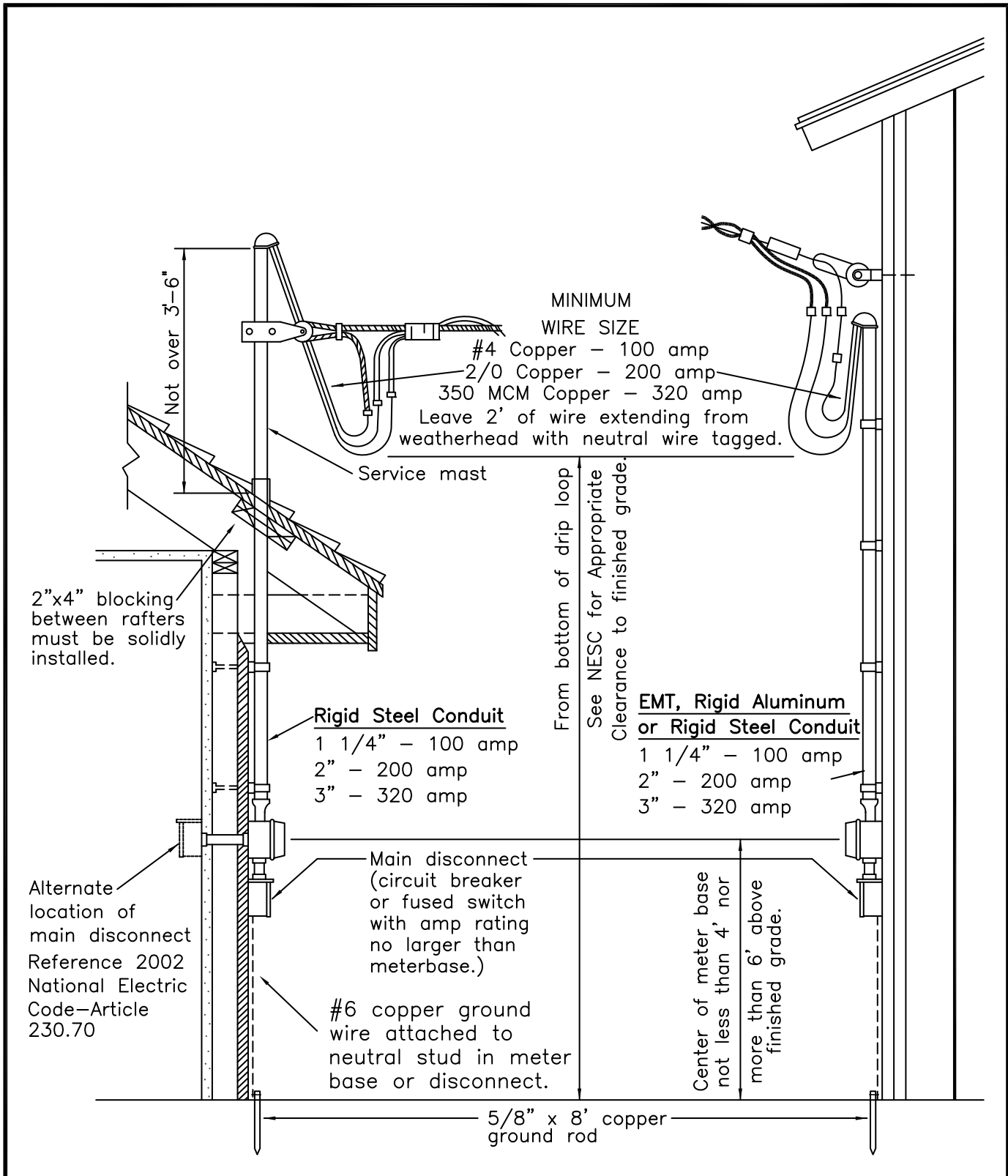

TYPICAL OVERHEAD SERVICE  
ENTRANCE ASSEMBLY GUIDE  
(FOR DWELLINGS)

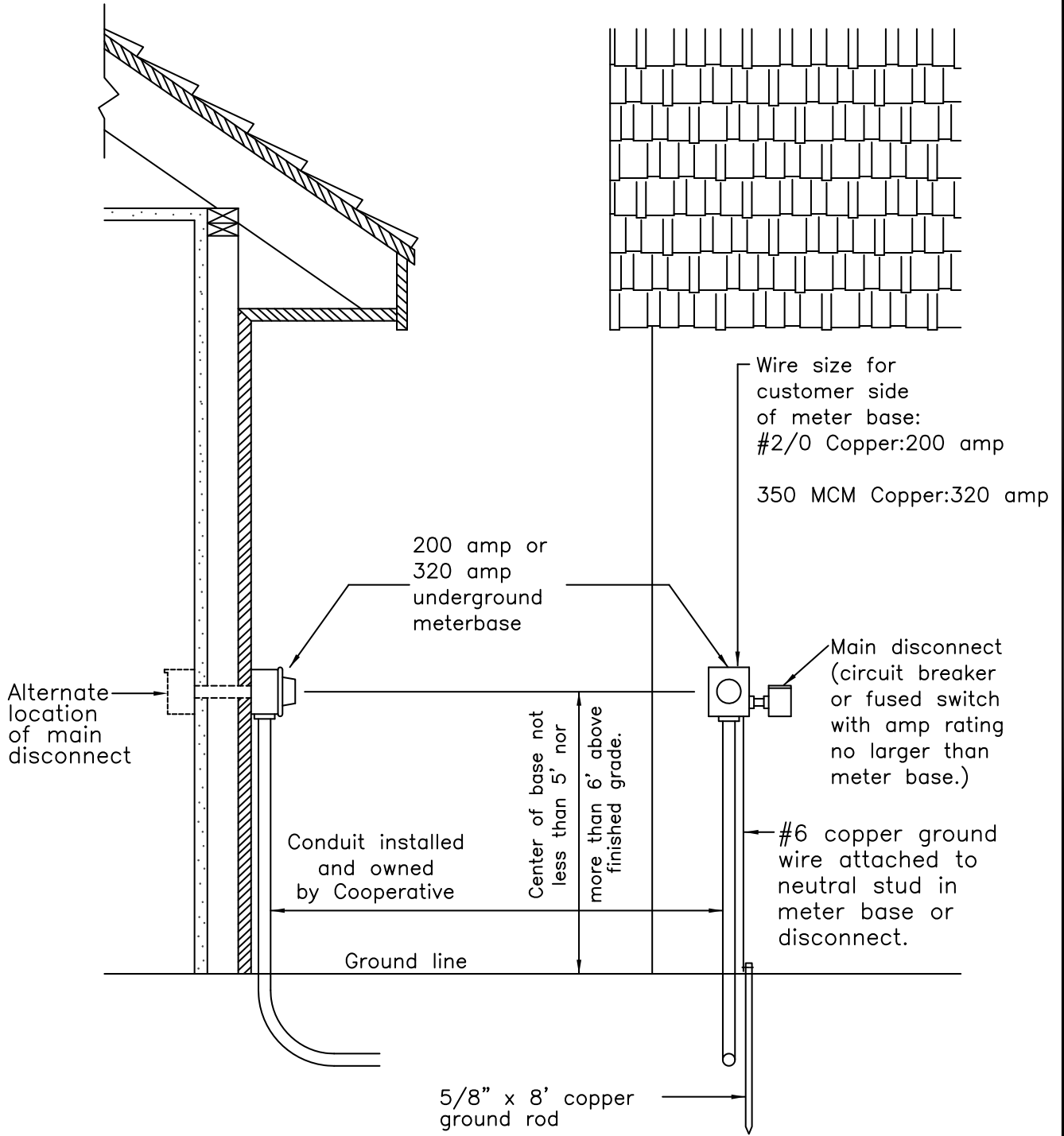

UNDERGROUND SERVICE ASSEMBLY GUIDE  
 (FOR DWELLINGS)

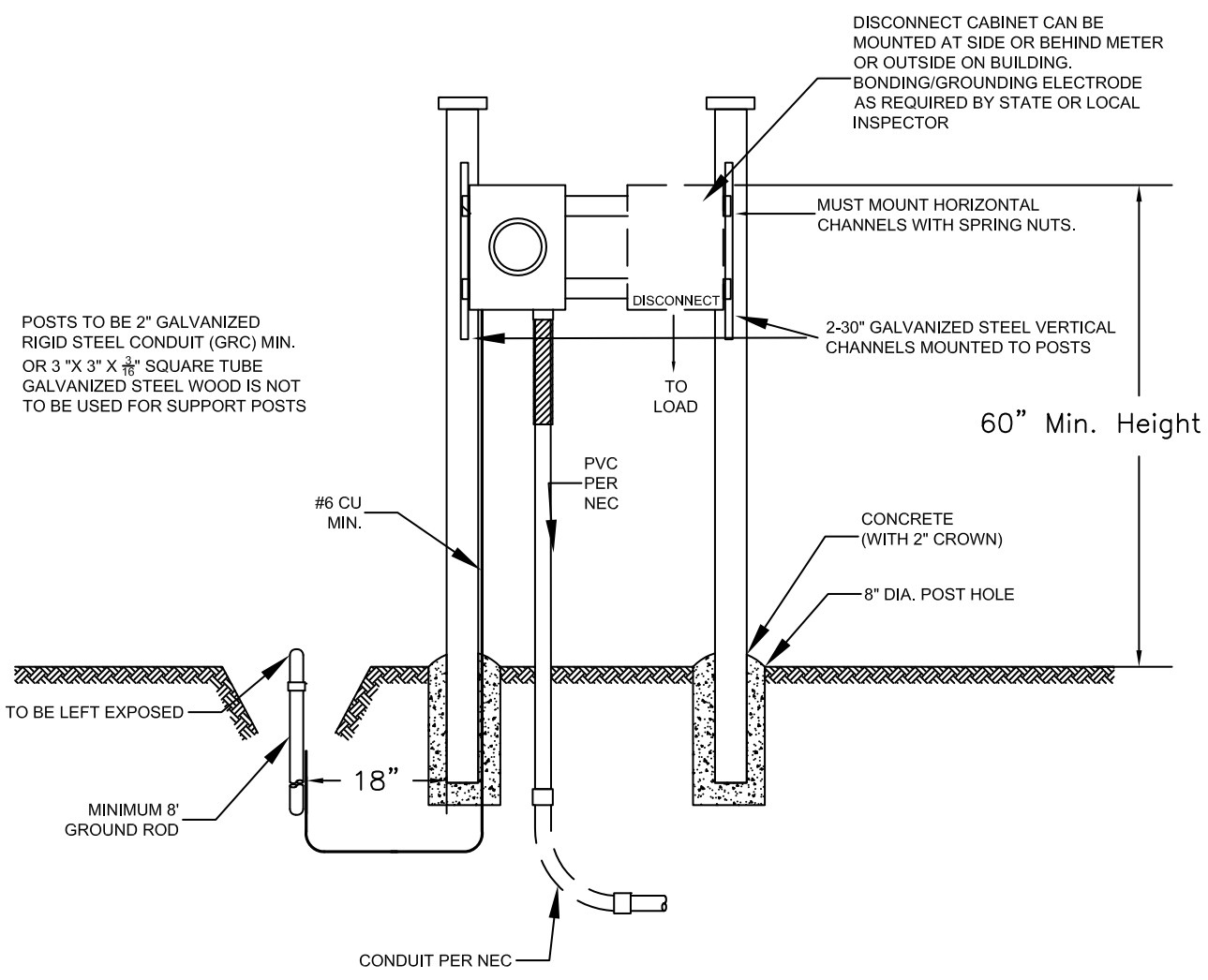

POSTS TO BE 2" GALVANIZED RIGID STEEL CONDUIT (GRC) MIN. OR 3" X 3" X 3/16" SQUARE TUBE GALVANIZED STEEL WOOD IS NOT TO BE USED FOR SUPPORT POSTS

TO BE LEFT EXPOSED  
MINIMUM 8' GROUND ROD

**METER NOTES:**

1. Cover plates or hubs for top of sockets should be purchased as needed at the same time as the sockets.
2. Assembly must be grounded per NEC.
3. PVC Conduit to be minimum 2" Schedule 80 with 36" radius 90degree sweeps.



200 Amp Self Contained Meter Rack

3/15	1 - PHASE PRIMARY 24.9/14.4 kV	UQ-1
------	-----------------------------------	------